

23341

M.Tech. 2nd Semester Embedded System & Design

Examination, May-2015

ANALOG IC DESIGN

Paper-MT-VLES-502

Time allowed : 3 hours] [Maximum marks : 100

Note : Attempt only five questions.

1. (a) Draw the O/P I-V characteristics of a MOSFET and explain it in terms of the operating principle of device. 10
- (b) What are the two main types of noise of MOSFET? How these noise can be eliminated? 10
2. (a) Explain the operation of common source stage with resistive load, diode and current source load. 10
- (b) Explain significance of Wilson and regulated cascade current mirror circuit. 10
3. (a) Derive an expression for voltage gain of source follower. 10

23341-P-3-Q-8 (15)

[P.T.O.]

23341

(2)

23341

- (b) For the circuit shown below, calculate O/P voltage for I/P voltage = 1.2 V and if I_1 is implemented using M_2 , find the minimum value of $\left(\frac{W}{L}\right)_2$ for which M_2 remains saturated. Assume $\left(\frac{W}{L}\right)_1 = \frac{20}{0.5}$

$$I_1 = 200 \mu\text{A}, V_{\text{THO}} = 0.6 \text{ V}, 2\phi_f = 0.7 \text{ V},$$

$$\mu_N \text{ COX} = 50 \mu\text{A}/\text{V}^2 \text{ and } \gamma = 0.4 \text{ V}^2 \quad 10$$

<http://www.HaryanaPapers.com>

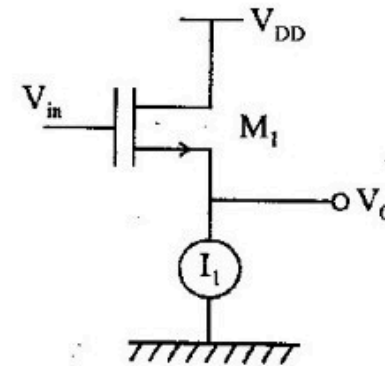

4. (a) Explain the design procedure of 2-stage CMOS OPAMP circuit. 10
- (b) Derive an expression for PSRR of CMOS OPAMP. 10

5. (a) Explain the working principle and operation of Gilbert cell. 10
- (b) Draw and explain frequency response of all single stage amplifiers. 10
6. (a) Explain various topologies used for feedback. Also explain effect of loading. 10
- (b) Explain frequency compensation techniques in detail. 10
7. (a) What is CMFB circuit ? What are various methods of designing CMFB circuits ? Compare them. 10
- (b) Explain the following specifications :
- (i) Differential Non-linearity
 - (ii) Integral Non-linearity
 - (iii) Gain Error. 10
8. Explain in detail :
- (i) Multi-finger transistors
 - (ii) Noise bandwidth and Noise figure
 - (iii) Offset cancellation. 20