

(4)

Section-D

8. A d.c. shunt motor runs at 1000 r.p.m. in 110 V supply. The armature and field resistance is of  $50 \Omega$  and  $0.4 \Omega$  respectively. The total current taken by the motor from the supply is 15 A. It is designed to reduce the speed to 750 r.p.m. keeping armature and field currents same. What resistance should be inserted in the armature circuit? 20
9. Explain the construction and operating principle of moving coil type instruments. 20

http://haryanapapers.com

Whatsapp @ 9300930012

Your old paper & get 10/-

पुराने पेपर्स भेजे और 10 रुपये पायें,

Paytm or Google Pay से

B.Tech. 1st Semester F-Scheme Examination,

December-2016

ELECTRICAL TECHNOLOGY

Paper-EE-101-F

Time allowed : 3 hours ] [ Maximum marks : 100

Note : First question is compulsory. Attempt five questions selecting at least one question each from four sections.

- (a) Differentiate between nodal and loop analysis.
- (b) What do you mean by peak factor.
- (c) Derive the relation between current and voltage in case of star and delta connection.
- (d) Derive the emf equation of D.C. generator. 20

Section-A

- Calculate the maximum power through  $6 \Omega$  resistance as shown in fig. 1 below : 20

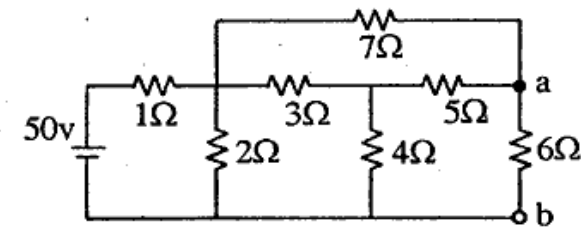

Fig. 1.

(2)

24007

3. Apply superposition theorem below fig. 2. 20

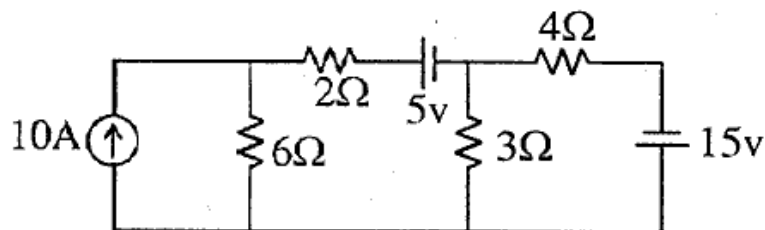

Fig. 2

**Section-B**

4. Calculate the voltage across section OP as shown if in fig. 3. 20

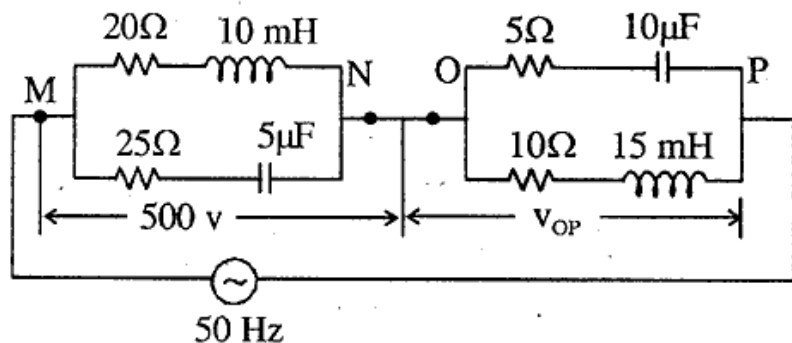

Fig. 3

24007

(3)

24007

5. A voltage source of frequency 5 k Hz is applied to an inductor in series with variable capacitor. When capacitor is set to 1.2 μF I has maximum value, while it is reduced to 1/3 rd when capacitor is charged to 6 μF. Find the value of the resistance of the coil and Q-factor. 20

**Section-C**

6. Explain the power measurement by two wattmeter methods in 3-φ. for unbalanced condition in details. http://haryanapapers.com 20
7. (a) A 1-φ transformer with ratio of 6 : 1 has primary resistance 5 Ω and reactance of 1.8 Ω and secondary resistance of 0.6 Ω and reactance of 0.2 Ω. Determine the percentage voltage regulation when delivering 120 A at 500 V at (i) 0.75 p.f lagging and leading. 10
- (b) The efficiency of 500 kVA, 1-φ transformer is 99.76% when delivering full load at 0.75 p.f and 98.33% at half load at unity p.f. calculate (i) Iron loss (ii) full load copper loss. 10